

VOLVO PV 544

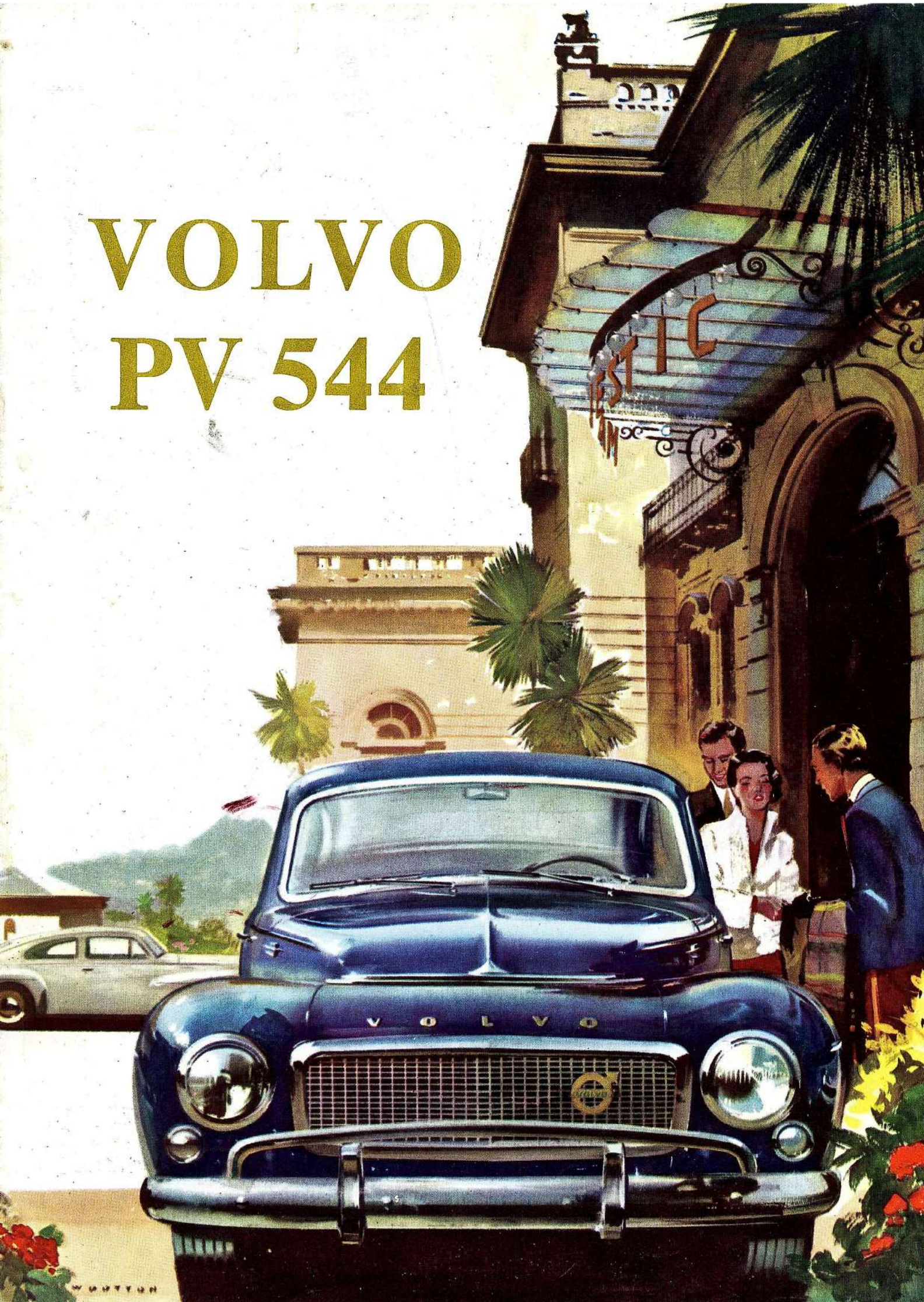

WOLFF



VOLVO

VOLVO PV 544 — the new family sports car

We are proud to present the Volvo PV 544 — a new version of the PV 444 — the car renowned for its repeated racing successes.

In spite of its outstanding sports characteristics, the PV 544 is first and foremost a family car. The new PV 544 has been designed specially for passenger comfort and safety.

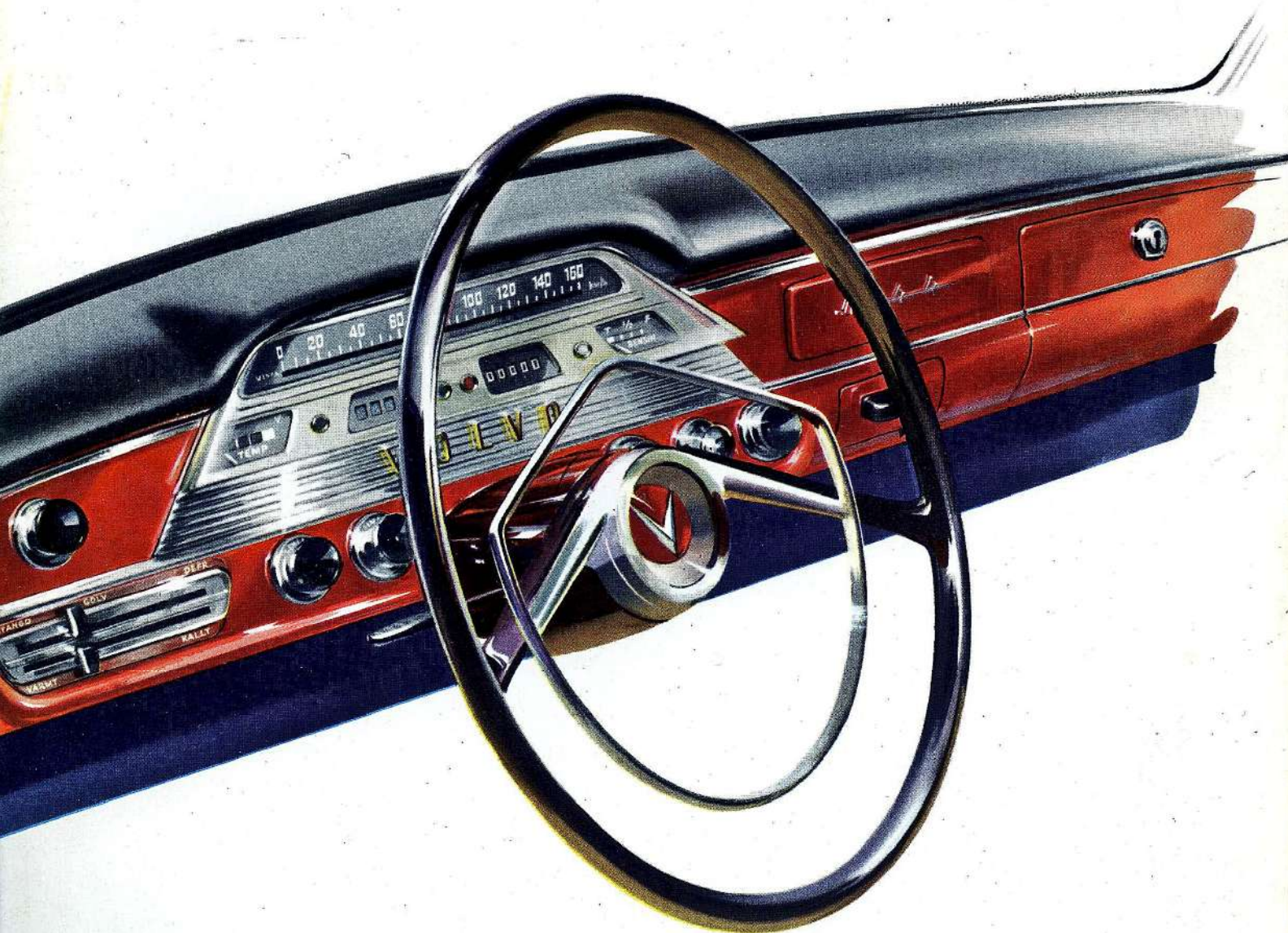

85 horsepower

sports engine with flashing acceleration

The economical twin-carburetor engine gives flashing acceleration and sparkling performance at really high speeds. This means quick starting and rapid, safe overtaking.

Max. output: 85 b.h.p. at 5,500 r.p.m.

Max. torque: 87 lb.ft. at 3,500 r.p.m.

Displacement: 97 cu.in.

Compression ratio: 8.2:1

The engine is fitted with a full-flow oil filter ensuring that the oil is always clean. Another advantage is that the oil only needs to be changed after every 3,000 miles.

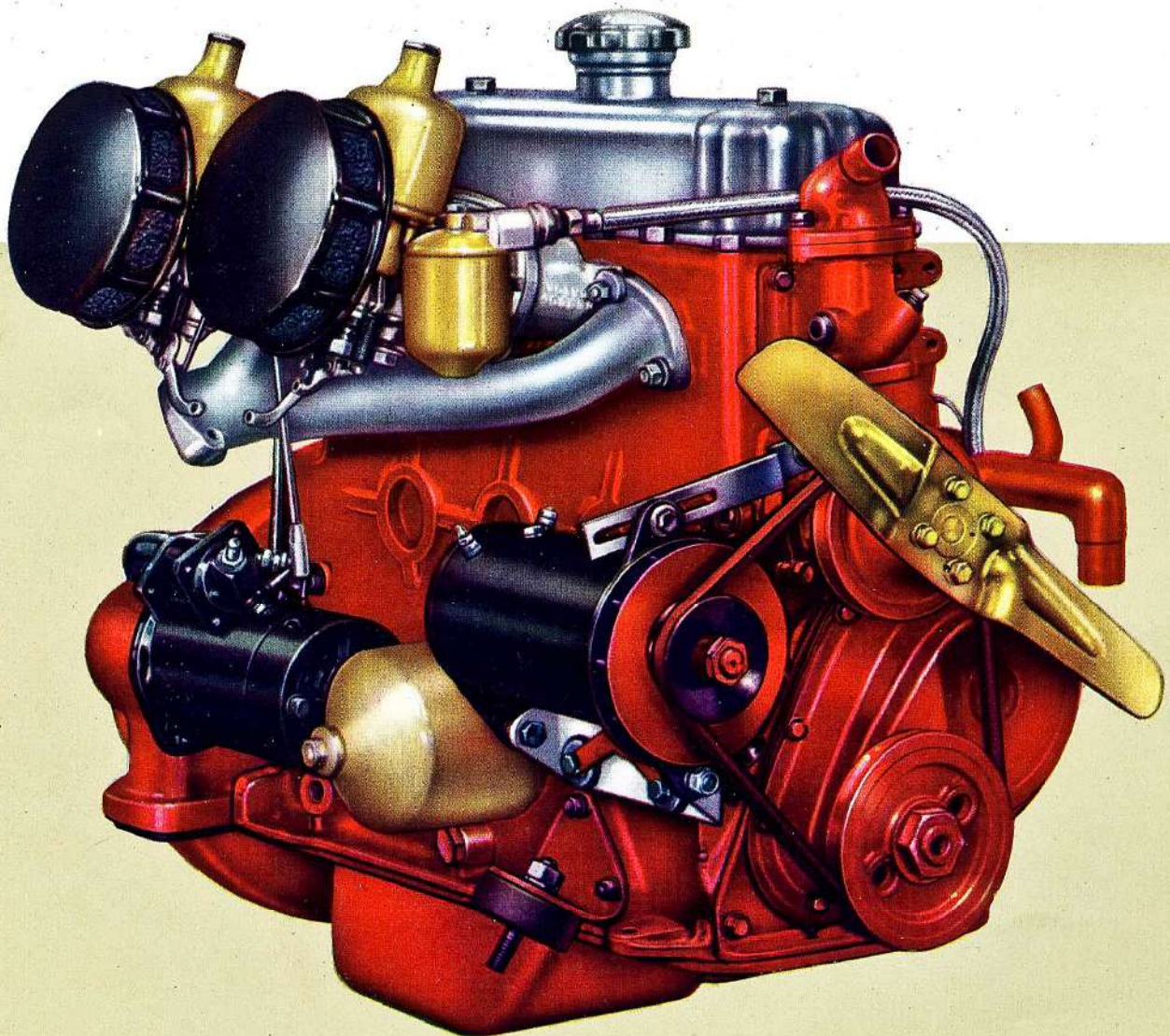

Specifications

Type designations:

P 54408 = model with four-speed transmission.
P 54409 = " " three-speed "

Engine: Type B 16 B four-cylinder, overhead-valve engine. Bore 3.125 in., stroke 3.15 in., displacement 97 cu.in., compression ratio 8.2:1. Output 85 b.h.p. at 5,500 r.p.m., torque 87 lb.ft. at 3,500 r.p.m. Twin SU horizontal carburetors. Full-flow oil filter.

Clutch: Spring-loaded single dry disk clutch.

Transmission: Four-speed, fully synchronized.
Optional: Three-speed transmission.

Propeller shaft: Divided propeller shaft for vibration-free operation. The center bearing is mounted in vibration-free, sound-insulating rubber blocks.

Front suspension: Independent front wheel suspension with coil springs and control arms. Double-action hydraulic shock absorbers.

Rear suspension: Coil springs. Rear axle with rubber-mounted support arms, torque arms and track rod. Double-action hydraulic shock absorbers.

Rear axle: Sturdy axle shafts in taper roller bearings. Hypoid final drive.

Steering: Hourglass worm and sector.

Brakes: Self-centering, hydraulic brakes of Duo-Servo type. Lining area 157 sq.in. Handbrake operates independently on rear wheels.

Tires: Tubeless, low pressure, whitewall tires 5.90-15".

Gasoline tank: Capacity 9½ U.S. gallons.

Electrical equipment: Thief-proof armored cable between the ignition switch and the ignition coil. Fan-cooled generator (50 amp.). Sealed-beam headlamps. Battery, 6-volt, 85 amp.hr. capacity.

Instruments and controls: Temperature gauge, fuel gauge, speedometer with mileometer. Warning lamps for charging and oil pressure. Self-cancelling directional indicators (flasher type). Central handbrake lever. Central gearshift lever.

Standard equipment: Double electric windshield wipers. Nozzles for windshield washer. Two sun visors. Fresh air type heater with defroster. Ashtrays. Attachments for safety belts in both front and rear seats. Rear quarter ventilator windows. Comprehensive tool kit and jack. Spare wheel.

Dimensions and weight: Wheelbase 102½", overall length 177", front tread 51", rear tread 51¾", overall width 62½", height 60¼". Weight, including fuel, oil and water 2,140 lb.

The Volvo Company reserves the right to change specifications, designs and prices.

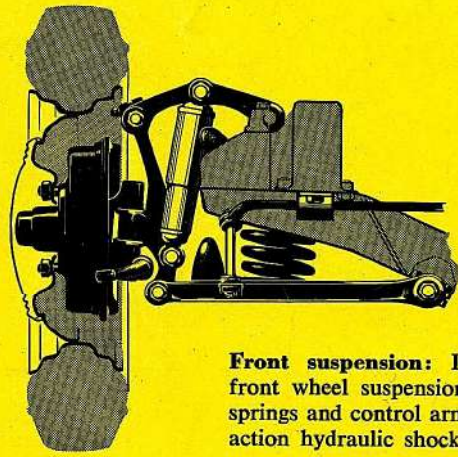

Front suspension: Independent front wheel suspension with coil springs and control arms. Double-action hydraulic shock absorbers.

Rear suspension: Coil springs. Rear axle with rubber-mounted support arms, torque arms and track rod. Double-action hydraulic shock absorbers.

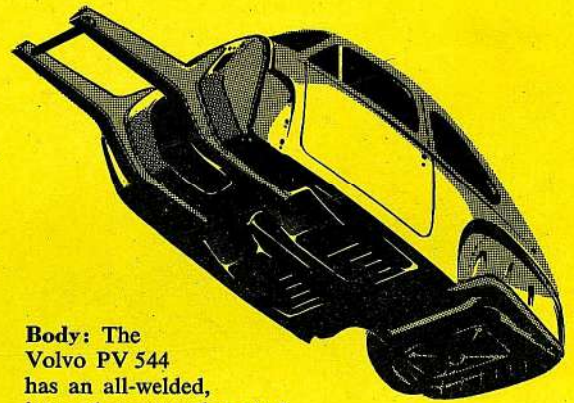
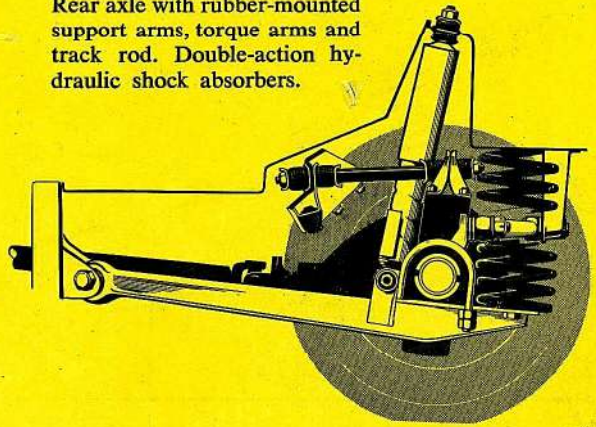

Body: The Volvo PV 544 has an all-welded, integral construction steel body which surrounds you with a steel shell of security. The body is rust-proofed and stands up to all weather conditions.

DEALER

AB VOLVO

Export Department

Gothenburg SWEDEN

ROTHLI'S FINEST AUTOMOBILES
2705 DIVISADERO ST. FRESNO, CALIF.

VOLVO PV 544 — the new family sports car

We are proud to present the Volvo PV 544 — a new version of the PV 444 — the car renowned for its repeated racing successes.

In spite of its outstanding sports characteristics, the PV 544 is first and foremost a family car. The new PV 544 has been designed specially for passenger comfort and safety.

New features in brief

- 1 Larger, one-piece windshield with slimmer pillars.
- 2 Wider and deeper rear window.
- 3 Roomier rear seat.
- 4 New, distinguished, padded instrument panel.
- 5 Thermometer type speedometer.
- 6 Handbrake between front seats.
- 7 New steering system.
- 8 New directional indicators.
- 9 Nozzles for windshield washer.
- 10 Suspended, vibration-free accelerator pedal.
- 11 New color and upholstery combinations.
- 12 Safety belt attachments for rear seat also.

Specifications

P 54408

Engine: Type B 16 B four-cylinder, overhead-valve engine. Bore 3.125 in., stroke 3.15 in., displacement 97 cu.in., compression ratio 8.2:1. Output 85 b.h.p. at 5,500 r.p.m., torque 87 lb.ft. at 3,500 r.p.m. Twin SU horizontal carburetors. Full-flow oil filter.

Clutch: Spring-loaded single dry disk clutch.

Transmission: Four-speed, fully synchronized.
Optional: Three-speed transmission.

Propeller shaft: Divided propeller shaft for vibration-free operation. The center bearing is mounted in vibration-free, sound-insulating rubber blocks.

Front suspension: Independent front wheel suspension with coil springs and control arms. Double-action hydraulic shock absorbers.

Rear suspension: Coil springs. Rear axle with rubber-mounted support arms, torque arms and track rod. Double-action hydraulic shock absorbers.

Rear axle: Sturdy axle shafts in taper roller bearings. Hypoid final drive.

Steering: Hourglass worm and sector.

Brakes: Self-centering, hydraulic brakes with automatic adjustment. Lining area 144 sq.in. Handbrake operates independently on rear wheels.

Tires: Tubeless, low pressure, whitewall tires 5.90-15".

Gasoline tank: Capacity 9½ U.S. gallons.

Electrical equipment: Thief-proof armored cable between the ignition switch and the ignition coil. Fan-cooled generator (50 amp.). Sealed-beam headlamps. Battery, 6-volt, 85 amp.hr. capacity.

Instruments and controls: Temperature gauge, fuel gauge, speedometer with mileometer. Warning lamps for charging and oil pressure.

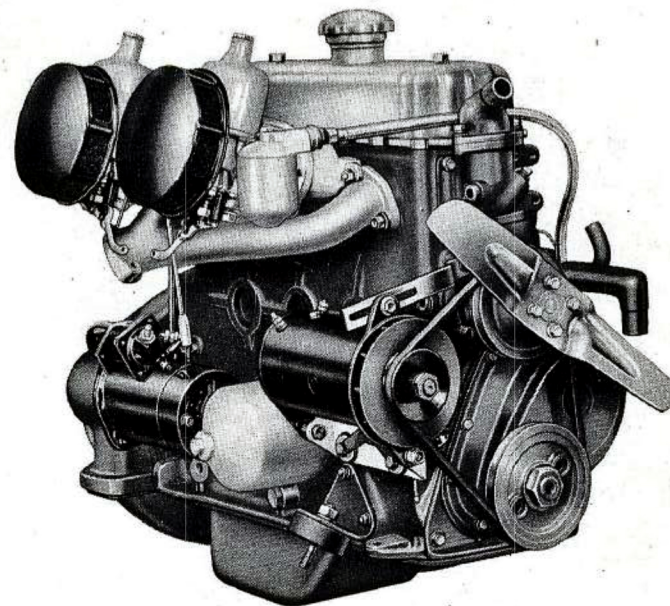

Self-cancelling directional indicators (flasher type). Central handbrake lever. Central gearshift lever.

Standard equipment: Double electric windshield wipers. Nozzles for windshield washer. Two sun visors. Fresh air type heater with defroster. Ashtrays. Attachments for safety belts in both front and rear seats. Comprehensive tool kit and jack. Spare wheel.

Dimensions and weight: Wheelbase 102½", overall length 177", front tread 51", rear tread 51¾", overall width 62½", height 60¼". Weight, including fuel, oil and water 2,140 lb.

The Volvo Company reserves the right to change specifications, designs and prices.

AB VOLVO

Export Department Gothenburg SWEDEN